

Connecting 6 Volt Batteries in Series for a 12 Volt System

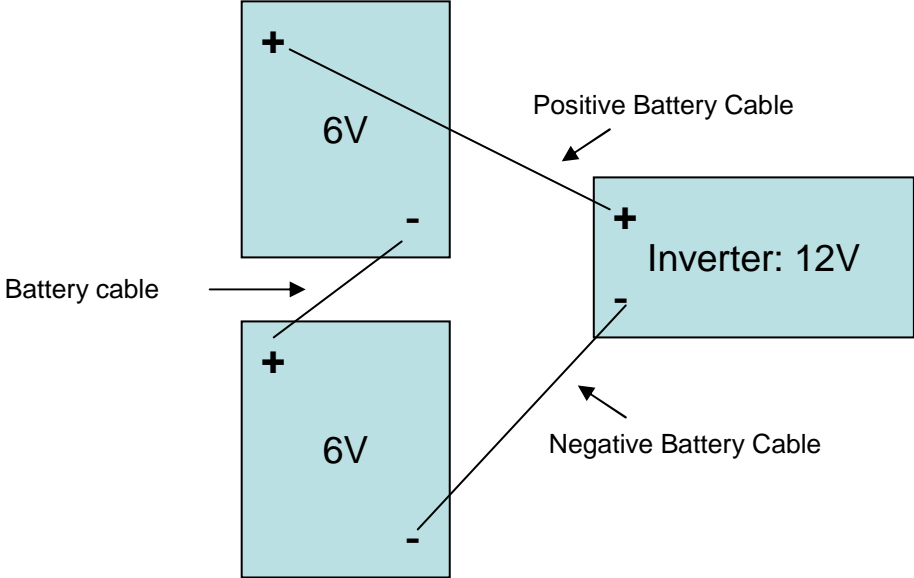

Connecting 6 Volt Batteries in Parallel and Series for a 12 Volt System

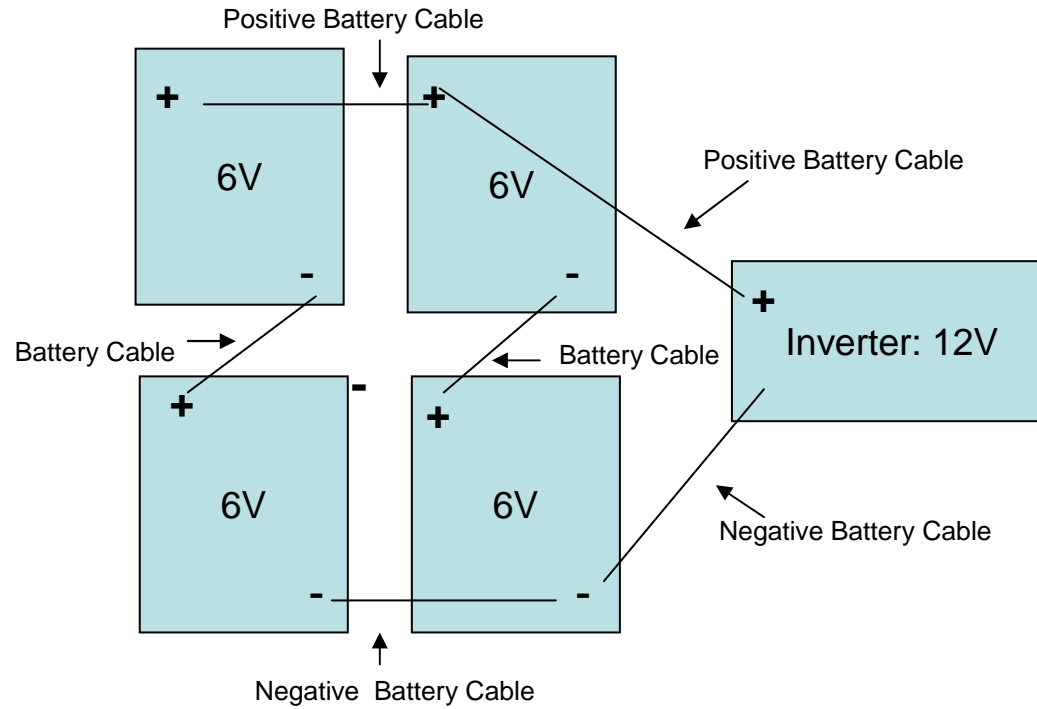

*You can use any amount of 6 volt series pairs of batteries in parallel. This example is for 4 batteries.

Connecting 12 Volt Batteries in Parallel for a 12 Volt System

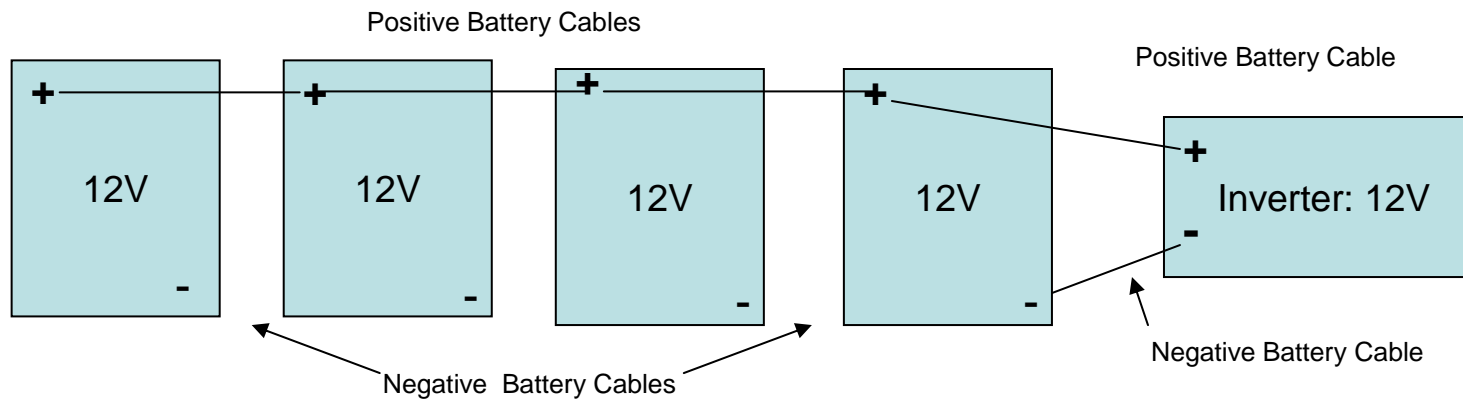

*You can use any amount of 12V batteries in parallel. This example is for 4 batteries. We recommend you limit your parallel strings. A failed cell in a parallel bank will use energy as the other cells try to charge it (all the time, which adds up in using excess energy). This can cause added heat which isn't good for batteries.

Connecting Batteries in Series for a 24 Volt System

Using 12 Volt Batteries

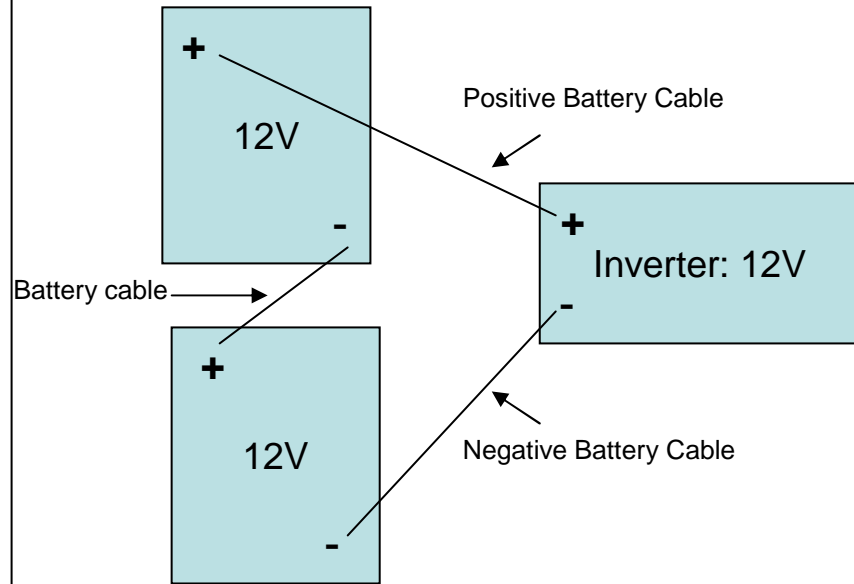

Using 6 Volt Batteries

